

GRU A MONTAGGIO RAPIDO
 GRUE A MONTAGE RAPIDE
 GRUA DE RAPIDO MONTAJE
 GRUA DE MONTAGEM RAPIDA
 QUICK SELFERECTING CRANE
 HYDRAULISCHER SCHNELLMONTAGEKRAN

Curve di carico – Courbes de charges – Load diagrams – LastKurven – Curvas de cargas

	3	25	29	m	OP	3	25	29	m			
	800	800	800	kg		1000	1000	1000	kg			
	3	10.3	12	16	20	24	28	31	m			
	4000	4000	3290	2290	1735	1380	1135	1000	kg			
	3		18.5	20	24	28	31	m				
	2000		2000	1865	1500	1240	1100	kg				
	3	15.5	16	20	24	28	31	m				
	2500	2500	2445	1865	1500	1240	1100	kg				
	3	11.3	14.4	m		3	14.4	m		3	14.4	m
	4000	4000	3000	kg		2000	2000	kg		2500	2500	kg

Reazioni – Reactions – Réactions – Eckdrücke – Reacciones

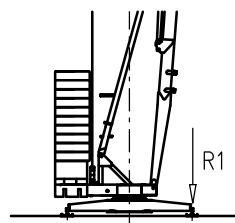

R1 ● 22 t ■ 15 t

▲ 12.7 t ○ 25.6 t

- | | | |
|-------------------------------|---------------------------------------|--------------------------------------|
| ● Reazioni in servizio | ● Reactions in service | ● Réactions en service |
| ■ Reazioni fuori servizio | ■ Reactions out of service | ■ Réactions hors service |
| ▲ Peso della gru senza assali | ▲ Dead weight without transport axles | ▲ Poids de construction sans essieux |
| ○ Peso zavorra rotante | ○ Ballast weight | ○ Poids du lest |
-
- | | | |
|--|--|---|
| ● Reaktionskräfte in betrieb | ● Reacciones en servicio | ● Em serviço |
| ■ Reaktionskräfte außer betrieb | ■ Reacciones fuera de servicio | ■ Fora de serviço |
| ▲ Konstruktionsgewicht ohne transportachse | ▲ Peso de la grua sin tren de transporte | ▲ Peso de la grua sem carro de transporte |
| ○ Ballastgewicht | ○ Peso de lastre | ○ Peso de lastre rotativo |



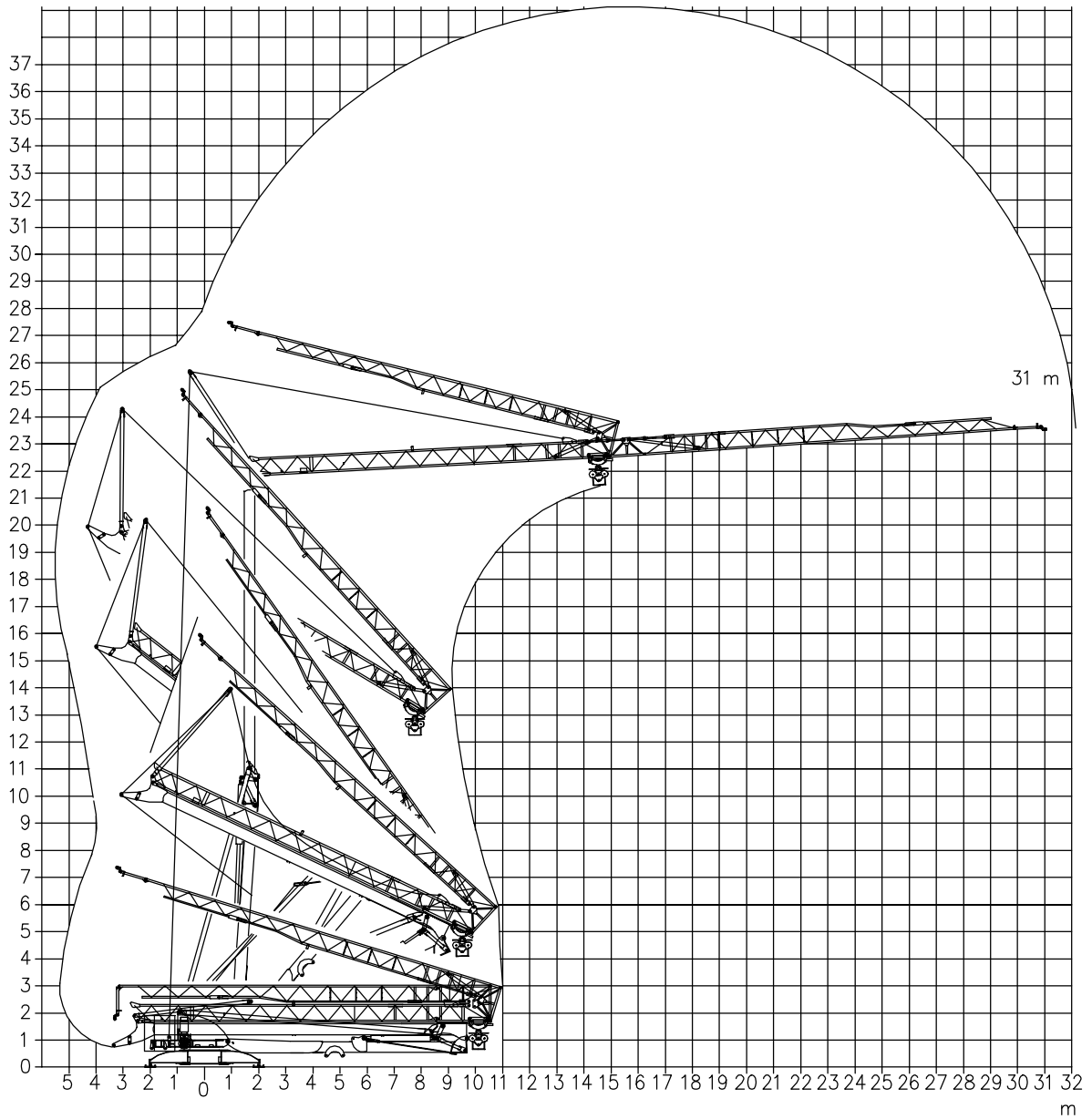

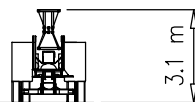
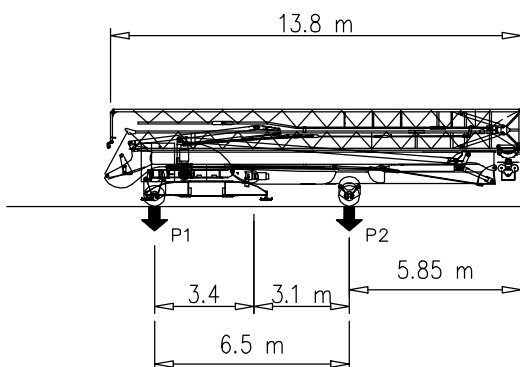

Montaggio – Montage – Erection – Montage – Montaje



Trasporto – Transport – Transport – Transport – Transporte



P1	Kg	9260
P2	Kg	9840
Ptot	Kg	19140

Sollevamento V12.40 Hoisting Elevaciòn	▲ ● ▼		1a	4 m/min	2000 kg	9 kW
			2a	20 m/min	2000 kg	
			3a	40 m/min	1100 kg	
			1a	2 m/min	4000 kg	
			2a	10 m/min	4000 kg	
			3a	20 m/min	2000 kg	
Sollevamento V15.45 Hoisting Elevaciòn			1a	4 m/min	2500 kg	11 kW
			2a	15 m/min	2500 kg	
			3a	25 m/min	2000 kg	
			4a	45 m/min	1100 kg	
Carrello Trolleying Distribuciòn	◀ ▶		1a	5 m/min	4000 kg	2.2 kW / 3 kW
			2a	17 m/min	4000 kg	
			3a	34 m/min	2000 kg	
Carrello Trolleying Distribuciòn	◀ ▶		1a	5 m/min	800 kg	2.2 kW
			2a	17 m/min	800 kg	
Carrello Trolleying Distribuciòn	◀ ▶		1a	5 m/min	1000 kg	3 kW
			2a	17 m/min	1000 kg	
Rotazione Slewing Orientaciòn			1a	0 → 0.2	giri/min tr/min rp/min	2.2 kW
			2a	0 → 0.5		
			3a	0 → 0.8		

Rete elettrica – Réseau – Mains supply – Netzstrom – Red	400V – 50 Hz
Potenza elettrica necessaria – Puissance électrique nécessaire Necessary electric power – Anschlusswert – Potencia electrica necesaria	V12.40 18 kVA V15.45 20 kVA
Conforme alla direttiva 2000/14/CE sul livello acustico Conforme à la directive 2000/14/CE sur le niveau acoustique In compliance with the 2000/14/CE instruction on noise level Germäss EWG-Richtlinie 2000/14/CE über Schall-Leistungspegel Conforme con la directiva 2000/14/CE sobre el nivel acustico	DIN 15018